



Product Specification for Li-ion Polymer Battery

聚合物锂离子电池产品规格书

Model 电芯型号:351536

Prepared by 制定	Checked by 审核	Approved by 批准

Customer Approval 客户确认	Checked /date 审核/日期	Approval /date 确认/日期

惠州基安比新能源有限公司

HUIZHOU MARKYN NEW ENERGY CO.,LTD.

电话: 0752-6688061

传真: 0752-6688063

TEL: 0752-6688061 FAX: 0752-6688063

<http://www.gmbattery.com>



SPECIFICATION AMENDMENT RECORDS

规格书变更记录

Edition 版本	Description 描述	Date 日期	Approved 审核
A0	New release (初版发行)	2014-5-13	huhongying
A1	Change the length for the wires 修改线长, 由 25mm 改成 15mm	2014-5-27	huhongying
A2	Modify the cut-off voltage, charge current and max. Discharge current 调整截止电压, 充电电流和最大放电电 流	2014-5-28	huhongying
A3	Modify the spec. For nominal capacity 调整标称容量的特性	2014-5-29	huhongying
A4	Change the printing part number on the cell 修改喷码型号	2014-6-18	huhongying
A5	Change all part number from 261534 to 351536, increase the drawing for single cell	2014-6-18	huhongying



1. Scope 适用范围:

This document describes the Product Specification of the Li-Polymer Rechargeable Battery supplied by Huizhou Markyn New Energy Co., LTD.

本规格书描述了惠州基安比新能源有限公司的可充电锂离子聚合物电池的产品性能指标。

2. Description 说明

2.1 Description: Li-Polymer Battery

类型: 锂离子聚合物电池

2.2 Model:351536

型号: 351536

3. Specification 产品规格

3.1 Basic Performance 基本性能

No. 序号	Item 项目	Spec 特性	Note 备注
1	Nominal Capacity 容量	$\geq 100\text{mAh}@ 0.5\text{C}$ Discharge(放电)	0.5Crate,2.8V cut-off
2	Nominal Voltage 标称电压	3.7V	
3	MAX Charge Voltage 充电限制电压	4.2V	
4	Discharge Cut-Off Voltage 放电截止电压	2.8V	
5	Charge current 充电电流	标准充电 Standard charge: 0.5C 快速充电 Rapid charge: 1C	
6	Standard charging 标准充电	0.5C 恒流充电至 4.2V, 再 4.2V 恒压充电至充电电流 $\leq 0.02\text{C}$ 0.5C CC (constant current) charge to 4.2V, then 4.2V CV(constant voltage) charge till charge current decline to $\leq 0.02\text{C}$	
7	Discharge Current 放电电流	Standard Discharge: 0.5C 标准放电电流: 0.5C Max Discharge: 2C 最大放电电流: 2C	
8	Storage temperature 储存温度	1 month 1 个月: $-10\sim 45^{\circ}\text{C}$ 6 month 6 个月: $-10\sim 35^{\circ}\text{C}$ $20\pm 5^{\circ}\text{C}$ is recommend long term storage temperature 推荐长期储存温度 $20\pm 5^{\circ}\text{C}$	



产品规格书
Product Specification

9	Weight 重量	Approx:3.2g 约: 3.2g	
10	Operating temperature 工作温度	Charging 充电: 0~+45 °C, 湿度 ≤ 85%RH Discharging 放电: -10~+60 °C, 湿度 ≤ 85%RH	禁止 0 度以下充电 <0°C Charge shall be prohibited
11	Cell Voltage 电池出货电压	3.8 ~ 4.00V	As of shipment 运输

4. Battery Cell Performance Criteria 电芯性能标准

4.1 Standard testing environment 标准测试环境

Unless specifically stated otherwise, tests must be done within one month of delivery and the number of charging-recharging cycles is fewer than 5. The following is test conditions:

Test conditions:

Ambient Temperature: 23°C ±2°C

Ambient Humidity: 65±20%RH

除非另有说明，测试应在电池出货的 1 个月内进行，且充放电循环的次数少于 5 次。本产品规格书中的所有测试均在以下环境条件下进行：

温度： 23°C ± 2°C

湿度： 65±20%RH

4.2 主要电性能 Electrical Characteristics

NO 序号	Item 项目	Test Method 测试方法	Criterion 性能标准
1	Visual inspection 外观	visual inspection 目测	Not allowing any visual defects which will affect the electronic characteristics, such as leakage and damage. 不允许有影响电芯性能的外观缺陷，诸如泄漏、损坏等
2	Battery Dimension 电池尺寸	Digital Calipers 数显卡尺	Length 长度: 36.0mm Max Width 宽度: 15.5mm Max Thickness 厚度: 3.5mm Max
3	Initial Impedance 初始内阻	Internal resistance measured at AC 1KHz after 50-60% charge 半电状态下，测量其 AC 1KHz 下的交流阻抗	≤380mΩ
4	Rated Capacity 初始放电容量	The capacity means the discharge capacity of the cell, which is measured with discharge current of 0.5C with 2.8V cut-off voltage after the standard charge.	≥100mAh



产品规格书
Product Specification

		该容量是指标准充电后，0.5C 放电至 2.8V 截止电压所放出的容量。	
5	Cycle Life 循环寿命	<p>Test condition: Charge: 0.5C to 4.2V Discharge: 0.5C to 2.8V When the discharge capacity reduced to 80% of rated capacity, Stop testing</p> <p>测试条件: 充电: 0.5C 充电到 4.2V 放电: 0.5C 放电到 2.8V 当放电容量降至额定容量的 80%时, 停止测试。</p>	The cycle times is not less than 300 循环次数不小于 300 次
6	High Temperature 高温放电容量	<p>A charged battery is placed in an oven for 2hours at 55°C±2°C, then discharged at a 0.5C current to the termination voltage.</p> <p>在 55°C±2°C 条件下, 将标准充电后的电芯放入高温箱中 2h 后, 再以 0.5C 电流放电至终止电压。</p>	Discharge 90 percent of the original capacity. 可放出初始容量的 90%
7	Low Temperature 低温性能	<p>A charged battery is placed in a thermal chamber for 4 hours at -10°C±2°C; then discharged at 0.5C to the termination voltage.</p> <p>在-10°C±2°C 条件下, 将标准充电后的电芯放入低温箱中 4h 后, 再以 0.5C 电流放电至终止电压。</p>	Discharge 60 percent of the original capacity. 可放出初始容量的 60% (-10°C) 以上
8	Electricity maintenance 荷电保持	<p>After the standard charging, storied the cells under the condition as 20±5 °C for 30days, then measured the capacity with 0.5C till 2.8V</p> <p>标准充电后, 在 20±5 °C 条件下贮存 30 天, 再以 0.5C 放电至 2.8V 所放出的容量。</p>	Remaining capacity ≥ 85% 剩余容量 ≥85%



产品规格书
Product Specification

4.3 Environment Characteristics 环境性能

NO 序号	Item 项目	Test Method 测试方法	Criterion 性能标准
1	Constant temperature and constant humidity test 恒定湿热	<p>After Standard Charging, test condition: Temperature: 40±2℃ Relative Humidity: 90~95%RH Storage Time: 48 hours Then return to room temperature for 2 hours, Then 1C discharged to ending voltage</p> <p>标准充电后, 测试条件如下: 温度: 40±2℃ 相对湿度: 90~95% 放置时间: 48 小时 电芯取出在室温下放置 2 小时, 然后以 1C 电流放电至终止电压。</p>	<p>No explosion , no fire , no leakage. Discharging capacity is not less than 60% original capacity</p> <p>不起火、不爆炸、不泄漏。 放电容量不低于初始容量的 60%</p>
2	Vibration test 振动	<p>After Standard Charging, fixed the cell to vibration table, then subjected to vibration test for 30 minutes per axis of XYZ axes. Frequency rate :1 oct/min Vibration frequency : 10Hz-30Hz Excursion(single amplitude): 0.38mm Vibration frequency : 30Hz-55Hz Excursion(single amplitude): 0.19mm</p> <p>电芯标准充电后, 固定在振动台上, 然后沿 XYZ 每个坐标方向振动 30 分钟 扫频速率: 1 oct/min 振动频率: 10Hz-30Hz 位移幅值 (单振幅): 0.38mm 振动频率: 30Hz-55Hz 位移幅值 (单振幅): 0.19mm</p>	<p>No explosion, no fire, no leakage 不起火、不爆炸, 不泄漏。</p>
3	Drop Test 跌落测试	<p>A charged battery is dropped from a height of 1 meter two times onto a concrete surface.</p> <p>标准充电后, 将电芯 2 次从 1 米的高度跌落至混凝土地面。</p>	<p>No explosion, no fire, no leakage. 不起火、不爆炸, 不泄漏。</p>



产品规格书
Product Specification

4.4 Safety Characteristics 安全性能

NO 序号	Item 项目	Method 测试方法	Criterion Test 性能指标
1	Overcharge test 过充电性能	Discharge : 1C to 2.8V Charge : 3C to 4.6V Stop the test when the surface temperature of the cell decays to about 20% from the maximum or continuous charging time up to 7 hours. 放电: 1C 放电至 2.8V 充电: 3C 充电至 4.6V 电芯表面温度比峰值低约 20%，或者持续充电时间达到 7 小时后停止测试	No explosion, no fire 不起火、不爆炸
2	Short-circuit test 短路	After Standard Charging , Short circuit the positive and negative , and the resistance of copper wire is not more than 80mΩ, Stop the test when the surface temperature of the cell decays to about 20% from the maximum or short time reach 24 hours. 标准充电后，使用总内阻不大于 80mΩ的导线短路正负极，当电芯表面温度比峰值低约 20%，或者短接时间达到 24 小时后停止测试。	No explosion, no fire 不起火、不爆炸
3	Thermal test 热冲击	Put cell into an hot box, test condition: Temperature Rate : 5±2 /min °C Ending temperature :130 ±2 °C Keep temperature for 30 minutes , Then stop testing. 将电芯放置于热箱中，测试条件如下： 升温速率: 5±2 /min °C 保持此温度 30min，然后停止测试。 终止温度: 130 ±2 °C	No explosion, no fire 不起火、不爆炸

Note: Above testing of safe characteristics must be with protective equipment.

备注：以上安全性能实验应在有保护措施的条件下进行。

5. Storage and others 贮存及其它事项

5.1 Long term Storage 长期贮存

If the cell is to be stored for 3 months or longer it should be held in a dry and cool environment. Voltage during storage needs to be maintained between 3.6V~3.9V and the storage conditions are the same as 20±5°C.

长期贮存的电池(超过 6 个月)须置于干燥凉爽处，储存电压应保持在 3.6~3.9V，且储存要求为 20±5°C

5.2 Any issues not covered in this specification should be discussed between the customer and GMB.

本说明书中未提及的任何事项，须经双方协商确定。



6. Warranty 保质期

Warranty period for this product is 6 months starting from the data that the batteries are shipped out from GMB factory (the printing date on the cell).

产品保质期为 6 个月，自出厂日期（喷码）开始算起。



7.Drawing

7.1 Assembly diagram (not to scale)

装配尺寸图(未按比例)

Model: 351536 Unit: mm

Cell size 单电芯尺寸图:

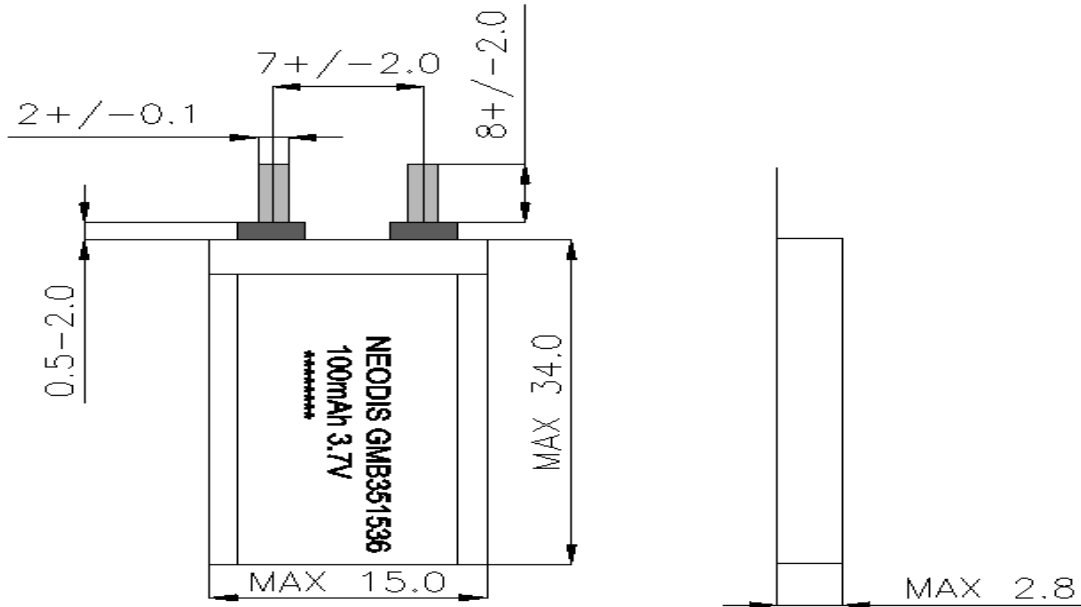

Battery size:成品电池尺寸:

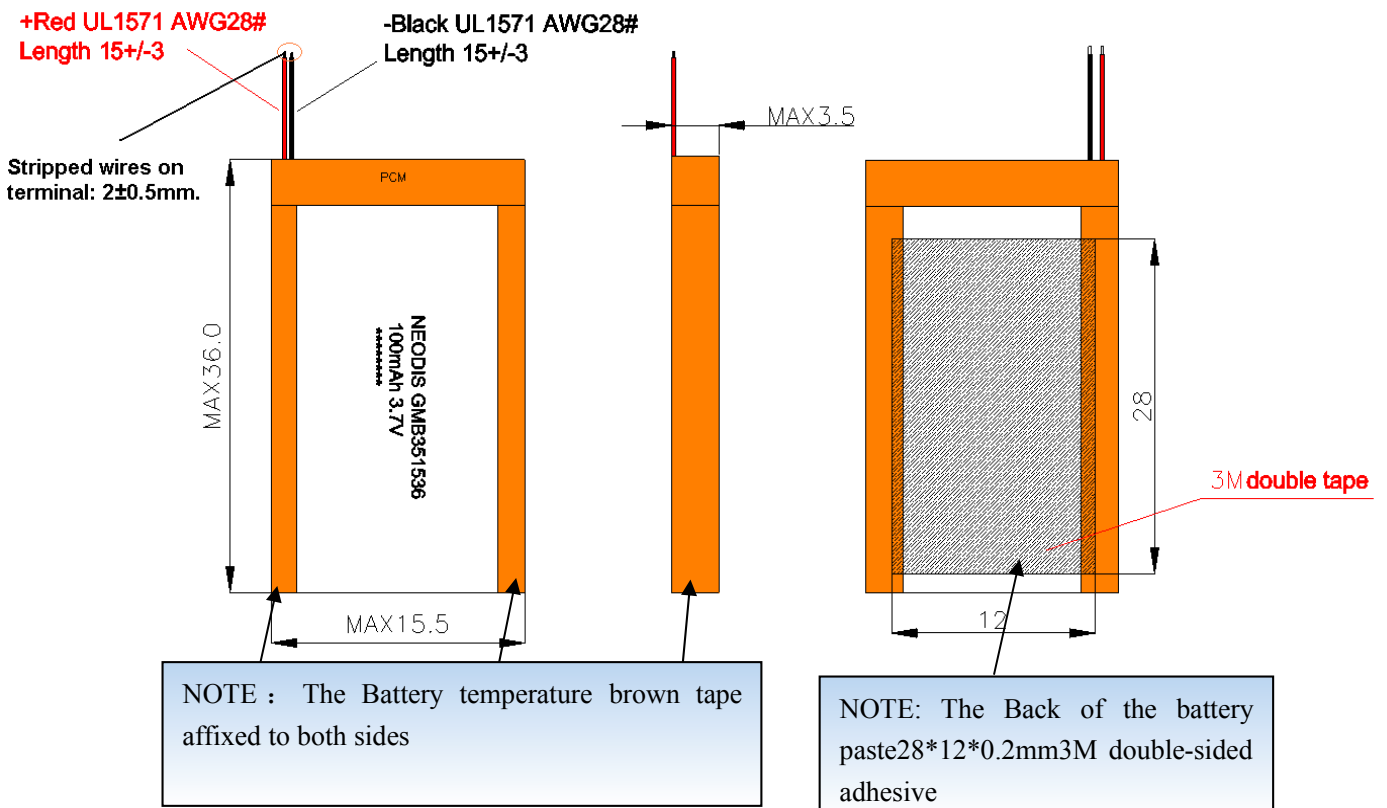

- Connecting Wires:
- Red: connect to “+”
- Black : connect to “-”



7.2、Protection Functions

7.2.1 PCM parameter PCM 参数

NO.序号	Item 项目	Specifications 规格
1	Over-charging Protection 过充保护电压	4.30±0.05V
2	Over discharge protection voltage 过放保护电压	2.4±0.1
3	Over current protection current 放电过流保护电流	2.0~4.5A
4	Current consumption (Operation) 正常状态下静态电流	≤6.0uA
5	Impedance 导通内阻	≤80mΩ
6	Operating temperature 工作温度	-20~55℃
7	0V battery charge function 0V 电池充电功能	Unavailable 禁止

7.2.2 Circuit Diagram 电路图

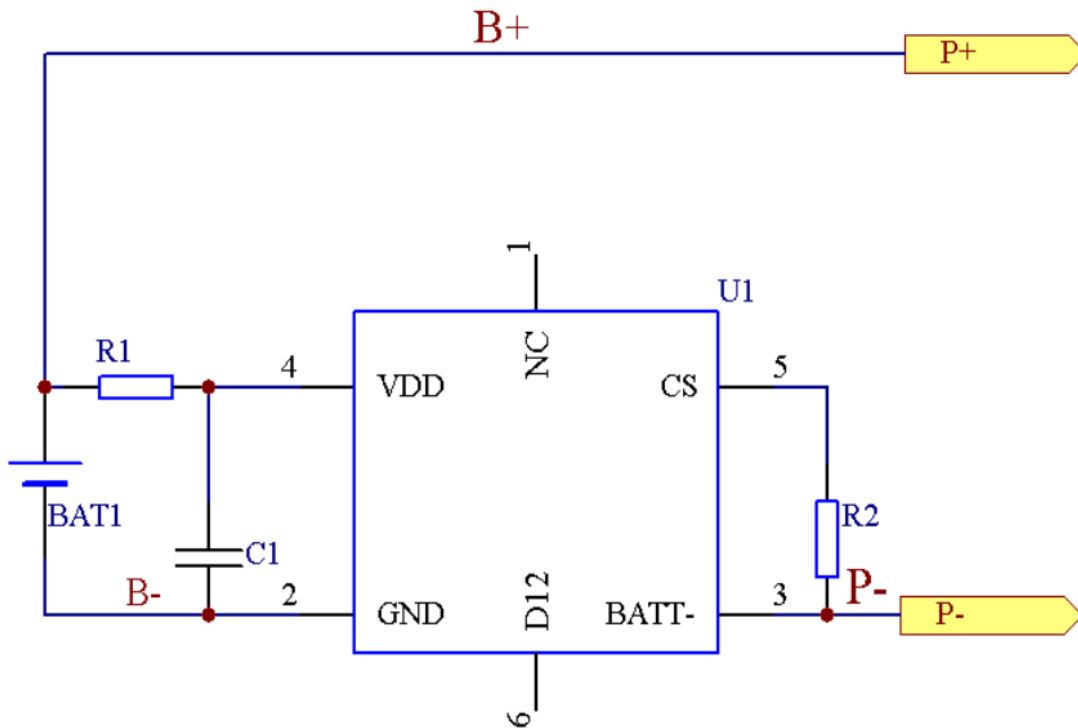

8、Packing drawing 包装图

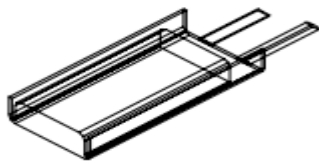

Cell

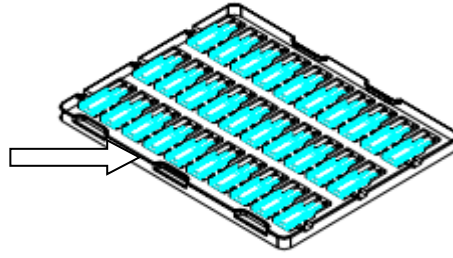

PVC tray

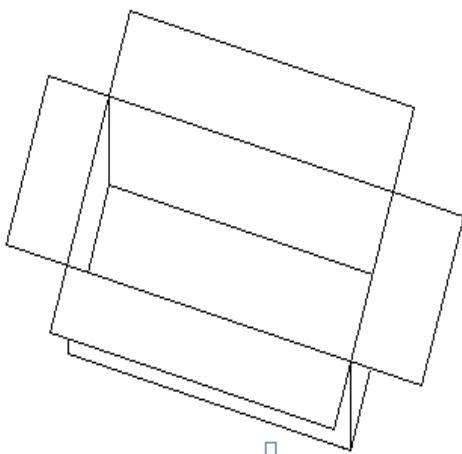

carton

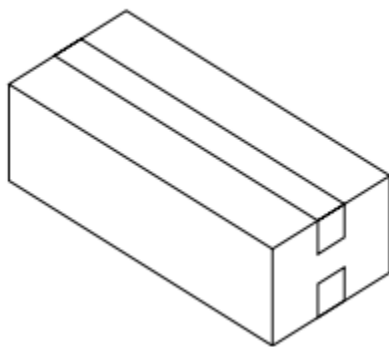
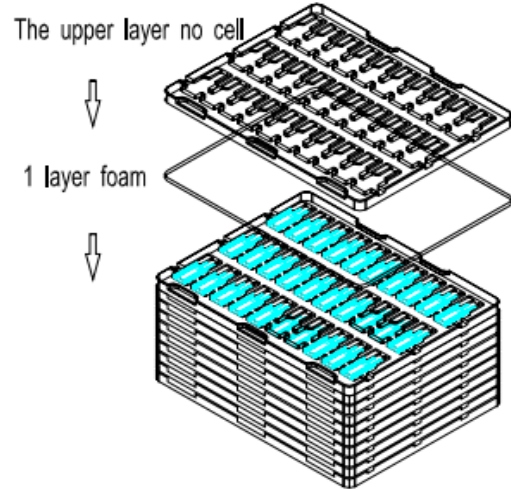

Sealing out carton

9、Warnings and cautions 警告及注意事项



产品规格书 Product Specification

Warning : Danger warning (it should be described in manual or instruction for users, indicated especially) to prevent the possibility of the battery from leaking, heating, explosion. Please observe the following precautions:

危险警告：（应在使用说明手册或说明书中，特别注明）为防止电池可能发生泄漏，发热，爆炸，请注意以下预防措施：

Do not disassemble or modify the battery.

严禁拆解或者修理电池。

Keep the battery away from children.

将电池放置在远离儿童的地方。

Do not touch a leaked battery directly.

严禁直接接触泄露的电池。

Do not use the battery with defect such as conspicuous damage or deformation.

严禁使用有明显的损伤或者变形等缺陷的电池。

Do not reverse the positive (+) and negative (-) terminals.

严禁将电池的正极（+）和负极（-）端子颠倒操作。

When recharging, use the battery charger specifically for that purpose.

必须使用为该电池专用配套的充电器充电。

Do not use or leave the battery near a heat source such as fire or heater.

严禁在明火或者其它热源附近使用电池，严禁将电池放在明火或者其它热源附近。

Do not short-circuit the battery by directly connecting the positive (+) and negative (-) terminals with metal objects such as wire.

严禁采用电线等金属物品直接短路电池的正极（+）和负极（-）端子。

Do not transport or store the battery with metal objects such as necklaces, hairpins etc.

严禁将电池和项链、发夹等金属物品一起运输或者一起存放。

Do not strike or throw the battery against hard surface.

严禁对着坚硬的表面敲击或者扔电池。

Do not directly solder the battery and pierce the battery with a nail or other sharp object.

严禁直接焊接电池，严禁使用钉子或者其它尖锐物刺穿电池。

Do not immerse the battery in water or seawater, and keep the battery in a cool dry environment during stands by period.

严禁将电池浸入水或者盐水中，不使用时请将电池保存在凉爽干燥的环境中。

Do not connect the battery to an electrical outlet.

严禁将电池和电源插座直接连接。



Do not dispose the battery in fire or heat.

严禁将电池投入火中或者热源中。

Do not use lithium ion battery and others different lithium polymer battery model in mixture

禁止与液态锂离子或不同型号的聚合物锂电池混合使用

Prohibition of use of damaged cells.

禁止使用已损坏的电芯

Don't bend or fold sealing edge. Don't open or deform folding edge Don't fillet the end of the folding edge.

禁止弯折顶封边，禁止打开或破坏折边，禁止导折电芯折边底部

Battery pack designing and packing Prohibition injury batteries.

电池外壳设计和包装禁止损伤电池。

Cautions 注意事项

Please read the specific charger manual before usage.

使用前请阅读具体的电池充电器说明书。

We suggest that using point welding to connect electrode and PCB is well, soldering or other welding method with long time heating electrode can make the battery leakage or sealing failure. 建议客户采用电阻焊的方式连接电极与保护电路，锡焊或其它长时间加热电极的焊接方式会导致电池密封的破坏。

Unless otherwise specified, the standard test temperature of the battery should be 23 ± 2 °C.

如无特殊说明，电池的标准测试环境温度要求为 23 ± 2 °C。

In case of long time storage(more than 3 months), the battery should be in a low humidity ,no corrosive gas area and at 20 ± 5 °C at half charged stage.

电池长期储存（3个月以上）情况下，应半充电状态储存在低湿度且不含腐蚀性气体的环境中，温度 20 ± 5 °C。

Charge the battery at operating temperature range of $0 \sim 45$ °C ,the cycle life of the battery will be shortened when charged at low temperatures.

请在 $0 \sim 45$ °C 温度范围内对电池充电，过低的温度条件下充电会缩短电池的循环寿命。

Discharge the battery at operating temperature range of $-10 \sim 60$ °C.

请在 $-10 \sim 60$ °C 温度范围内对电池放电。

Do not use or leave the battery at very high temperature (for example, at strong direct sunlight or in a vehicle in extremely hot weather).Otherwise, it can overheat or fire or its performance will be degenerate and its service life will be shortened.

不要在非常高温（如阳光直射或者高温的车辆内）的环境下使用或者放置电池，否则电池会过热、起火或者性能会退化，使用寿命会缩短。



Do not use the battery in a location where static electricity is rich, otherwise, the safety devices may be damaged, causing a harmful situation.

请不要在静电量大的地方使用电池，否则安全装置会被破坏，造成危险。

In case the electrolyte get into the eyes due to the leakage of battery ,do not rub the eyes, rinse the eyes with clean running water, and seek medical attention immediately .Otherwise, it may injure eyes or cause a loss of sight.

如果因电池电解液泄漏进入眼睛，请不要揉眼睛，用干净的自来水冲洗眼睛，并立即就医。否则，可能会损害眼睛或导致失明。

If the battery gives off an odor, generates heat, becomes discolored or deformed, or in any way appear abnormal during use ,recharging or storage ,immediately remove it from the device or battery charger and place it in a contained vessel such as a metal box.

如果在充电或储存过程中电池发出异味，发热，变色或变形，或以任何方式出现异常，立即将电池从设备或电池充电器中取出，并放置在诸如金属盒的容器中。

10. Special Notice 特别提醒:

10.1 If the cell isn't used for a long time, please keep the cells in a half-charged state neither fully charged and not completely discharged. Recharge the cells and use half of the power after 2-3 months. Store the cells in a cool and dry place. It will protect the cell from damage.

若电池长期不使用时，使其处于半充饱电状态(一半电量)，即:不充满电，也不放完电。并在 2-3 个月之后重新充电，并使用一半电量，电池应在阴凉干燥处储存，这样可以使电池不受损坏。

10.2 Any components contacting these two edges, they must be insulated.

导电元件与电池两侧封边接触必须绝缘。

11. Liability 责任书

The user has to operate the products according to the instructions printed on the battery label or follow the advices described in this “Lithium-ion Rechargeable Battery Specification” published by Huizhou Markyn New Energy Co., LTD. In case the battery were overheated or even catch fire or explosion caused by mishandling of the user side, Huizhou Markyn New Energy Co., LTD. will not be liable for the lose caused by any of such mishandling. The customer is requested to contact GMB in advance if and when the customer needs variations of the operating conditions described in this document. Additional experimentation may be required to verify performance and safety under such conditions.

用户必须按照电池标签上的说明或者此份惠州基安比新能源有限公司的可充电锂离子电池规格书来使用。如果由于用户的不当使用引起电池过热甚至起火或者爆炸等所造成的损失，惠州基安比新能源有限公司将不承担任何责任。客户若需要变动文件中规定的工作条件，应事先联系基安比新能源。需要额外进行试验以核实电芯在该使用条件下的性能及安全性。